

TRADEWASTE FOOD OIL INTERCEPTOR



FEATURES

All Purpose Pumps Food Oil Interceptor are ideal for commercial food preparation facilities, cafes, restaurants, and many other industrial food processing plants. Interceptors are designed to separate fats, oils and grease from waste water. The interceptors are constructed from Fibreglass (FRP) and are structurally engineered to withstand difficult ground conditions without failure whilst also being suitable for above ground applications.

- > Inground installation without the need for concrete backfill
- > Above ground installation
- > Adjustable riser
- > Fixed riser to increase installation depth (optional accessory)
- > Engineered lifting points
- > Multi interconnectable tank design for larger capacity

DESIGN AND CONSTRUCTION STANDARDS:

- > Melbourne Water Authorities approved
- > AS/NZS 1546.1 Soil loading design requirements
- > AS2634:1983 Chemical plant equipment made from GRP
- > IP Australian Design No. 201811669

ADJUSTABLE RISER:

- > Unique design helps achieve superior surface finish and reduces installation time by allowing easy ground topography alignment
- > Height adjustment up to 75mm
- > Angle adjustment up to 5 degrees

FRP PIT DESIGN LIFE:

- > Design life of 50 years



30 YEARS INDUSTRY EXPERIENCE

RANGE

CAPACITY	LENGTH	WIDTH	HEIGHT	A (INLET)	B (OUTLET)	C (VENT)	INLET OUTLET VENT DIA Ø	WEIGHT (EMPTY)	INLET DEPTH (INVERT)	
									MIN	MAX
600L	1810mm	845mm	1130mm	740mm	665mm	875mm	100mm	100kg	445mm	1000mm
1100L	1875mm	1195mm	1240mm	890mm	815mm	970mm	100mm	128kg	405mm	1000mm
2000L	2595mm	1280mm	1435mm	1065mm	990mm	1105mm	100mm	185kg	420mm	1000mm
3000L	2770mm	1555mm	1520mm	1160mm	1087mm	1200mm	100mm	240kg	415mm	1000mm
5000L	3375mm	1587mm	1880mm	1457mm	1380mm	1600mm	100mm	385kg	478mm	1000mm

TYPICAL ARRANGEMENT

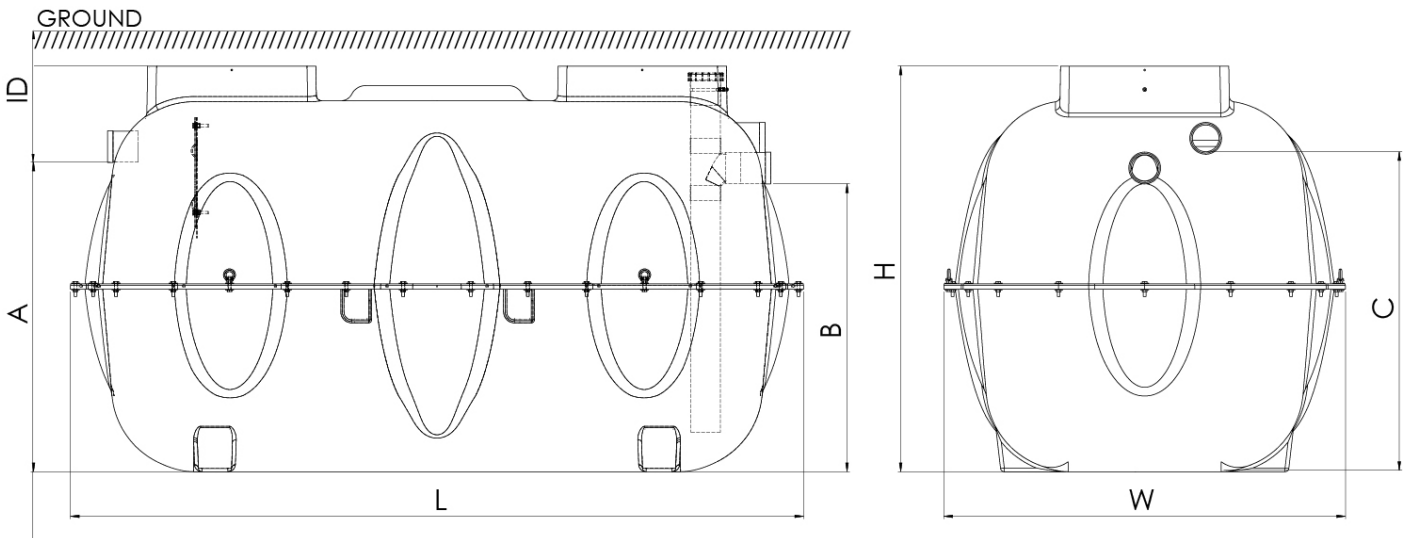

* Larger sizes and custom designs available upon request

ALL
PURPOSE
PUMPS
PRECISION
ENGINEERED
TO FLOW...



T +61 3 8368 0000
www.appumps.com.au

TRADEWASTE FOOD OIL INTERCEPTOR

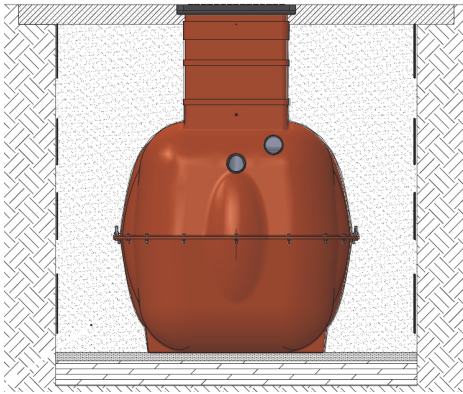

DESIGN:
No concrete backfill required for easiest installation

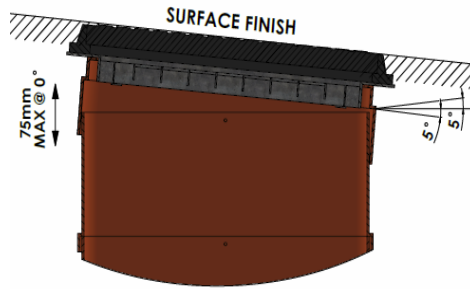

ADJUSTABLE RISER:
Unique riser designs for easy depth and surface alignments



ACCREDITATION:
Design approvals for confident and compliant installations

TRADEWASTE FOOD OIL INTERCEPTOR- ACCESSORY

FEATURES

FIXED RISER:

- > Achieve desired installation depth (max. 1000mm to inlet invert)
- > Stackable onto interceptor
- > Can be cut to height for accurate surface finish level

TYPICAL ARRANGEMENT

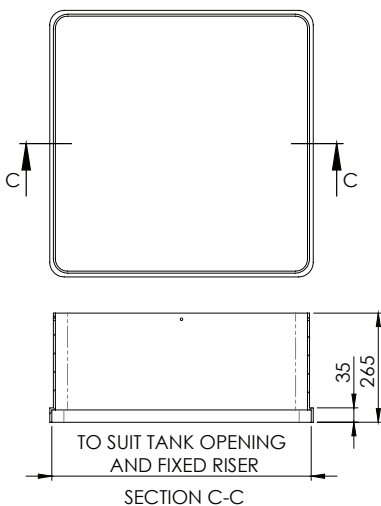

ADDITIONAL OPTIONS

COVER- METAL

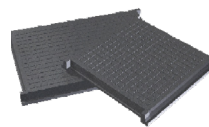

FRP LID

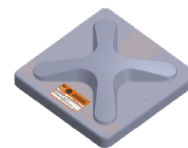

SAFETY GRATE

