

HYLIFT® UNDERSINK SULLAGE PUMPS

HYLIFT® 40



FEATURES

Compact and easy to install, the All Purpose Pumps HYLIFT® 40 units come fully assembled and plug directly into a standard electrical outlet. The heavy duty pump easily handles domestic and commercial waste and has been selected for its high performance & extremely quiet operation.

- > Durable 40 litre stainless steel tank.
- > 240v submersible pump, capable of handling small solids and fibres, whilst pumping high heads and long distances.
- > Compact design, supplied fully assembled with all connection points on one face.
- > Single trade installation, complete with 2 metre power cable and standard 3 pin, 240v 10 amp plug.
- > Integral odour filter and anti flood valve*
- > Optional audible visual high level alarm, 3 Mountable Positions voltage free common alarm output for BMS connection
- > 50mm FBSP Inlet
- > 25mm FBSP Discharge



25 YEARS INDUSTRY EXPERIENCE

RANGE

MODEL	PRODUCT CODE	PUMP	MAX. SOLIDS HANDLING	MAX. HEAD	VOLTAGE/KW	ADDITIONAL FEATURE
HYLIFT-40	865010	HV32	15mm	7.0m	240V / 0.18kW	-
HYLIFT-40HLA	865011	HV32	15mm	7.0m	240V / 0.25kW	High Level Alarm

PERFORMANCE

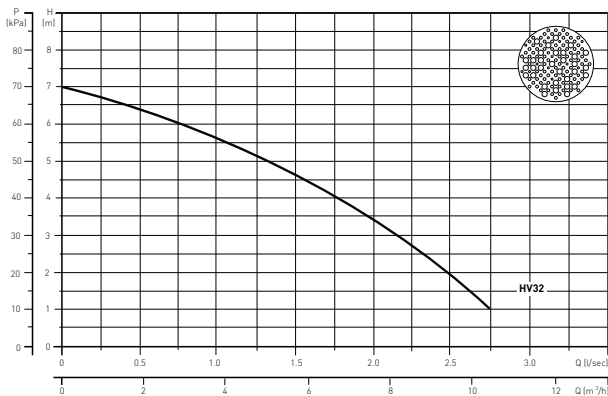

DIMENSIONS

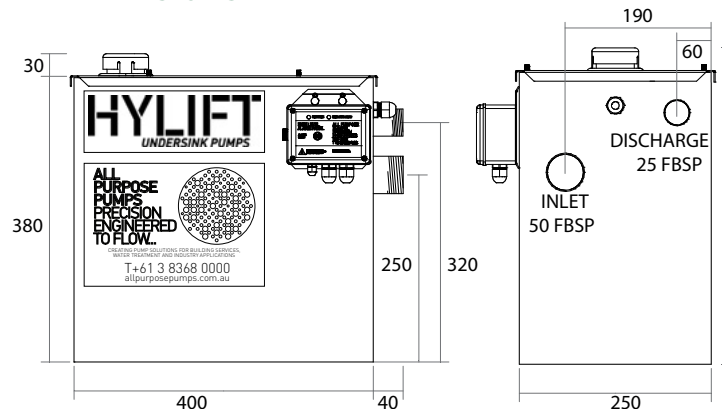

NOTES

1. Dimensions in mm and are approximate
2. Allow minimum of 200mm above unit for maintenance
3. High level alarm needs weather protection if mounted outside

HYLIFT APPLICATION GUIDELINE

Based on a typical office amenities application

HYLIFT 40	HYLIFT 70
<ul style="list-style-type: none"> > Tight spaces and less demanding applications > Suitable for 1-30 people with one dishwasher. 	<ul style="list-style-type: none"> > High-use applications including restaurants, large office spaces, greasy and fatty wastes. > Suitable for 1-80 people with two dishwashers.

FLOOD PROTECTION & SAFETY DEVICES

- > Audible / Visual High level alarm with flexible positioning (Optional) [see page 248]
- > Flood Prevention Safety interlock kits (Optional - Requires High Level Alarm) [see page 38 - 40]
- > Unique combined Odour Filter and anti flood valve. (see page 43)

APP ADVICE	FEATURE	BENEFIT
	Powerful & reliable pump	<ul style="list-style-type: none"> > No need to run pump line on grade > Handles solids and fibers > Multiple bends, rises and falls in the pump line is no problem
	Odour filter & anti flood valve	<ul style="list-style-type: none"> > Eliminates the need for vent pipework

*NOTE

1. Chemical, thinners and acidic based products will reduce the Filter service life

