

# HYFLOW® COMMERCIAL SUBMERSIBLE CONTRACTOR PUMP



## FEATURES

HYFLOW® Commercial - Submersible Contractors Pumps are designed for the construction industry. They are small, robust and portable in design, perfect for near complete eradication of water from building sites, flooded basements and more.

- > Heavy duty construction
- > Triplex seal system combines a SIC/SIC hard-face double mechanical seal and lip seal in a large capacity oil chamber
- > Moulded power cable base provides best protection against water ingress
- > Stainless Steel heavy rigid shaft for increased seal and bearing life
- > Motor overheat switch to assist in protecting the pump motor
- > 10 metre power cable (H07RFN submersible rubber power and float cable)

### HD DRAINAGE DESIGN

Rubber coated multi-vane semi-open impeller for high abrasion resistance 

### CASING & SUCTION COVER

Rubber coated for high abrasion resistance

### OUTLET CONNECTION

Multi position outlet to eliminate hose kinking



### APP ADVICE

### RECOMMENDATION



STANDARD HOSE  
KIT



LAY FLAT HOSE KIT



**30 YEARS** INDUSTRY EXPERIENCE

## HP25.04.1.2 (PUDDLE PUMP)

- > Removes water down to 1-2mm
- > Solids handling 2mm

### RANGE

MODEL NUMBER	PRODUCT CODE	OUTLET	POWER	CURRENT (FLC)	WEIGHT
HP25.04.1.2	190117	25mm	0.4kW	2.6A	11kg

### DIMENSIONS

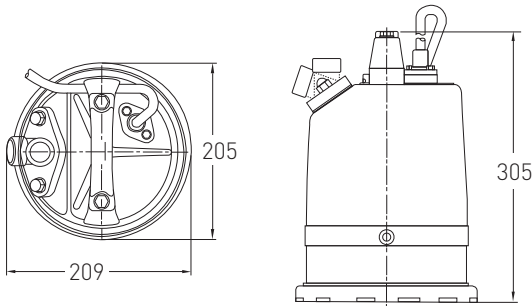

### PERFORMANCE

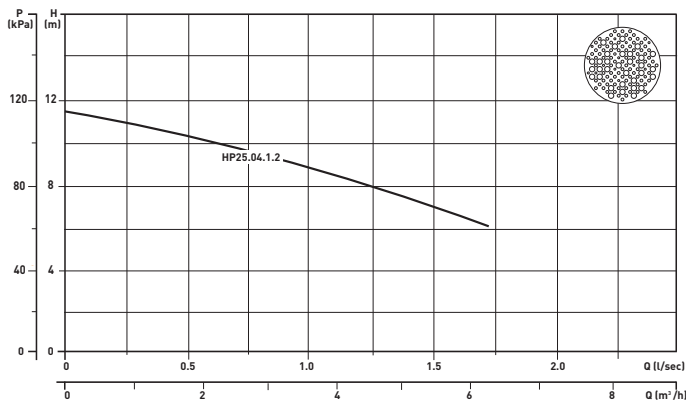

## HP50.075.1.2

- > Removes water down to 15mm
- > Solids handling 7mm

### RANGE

MODEL NUMBER	PRODUCT CODE	OUTLET	POWER	CURRENT (FLC)	WEIGHT
HP50.075.1.2	190118	50mm	0.75kW	5.0A	13kg

### DIMENSIONS

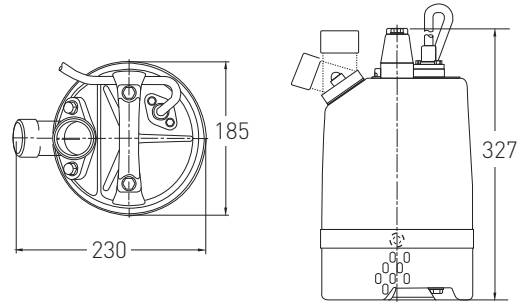

### PERFORMANCE

