

HYFLOW® COMMERCIAL SEWAGE GRINDER PUMP



FEATURES

The HYFLOW® Commercial Sewage Grinder Pump is suitable for waste water and sewage pumping requirements. Ideal for all domestic, urban and commercial applications making it the perfect solution for both temporary and permanent installations.

- > Cast iron construction with stainless steel motor housing and shaft
- > Level float switch for automatic operation
- > Duplex seal system combines a SIC/SIC hard-face mechanical seal and lip seal in an oil chamber for lubrication and cooling
- > Motor overheat protection to assist in protecting motor
- > 10 metre cable
- > Two pole induction motor



30 YEARS INDUSTRY EXPERIENCE

RANGE

MODEL	PRODUCT CODE	OUTLET	VOLTAGE	POWER	LOAD CURRENT	WEIGHT
G50.13.1A.2	190153	50mm	240v	1.3kW	8.2A	25kg

NOTE

1. For full motor protection, pumps must be protected by a manually resettable thermal overload device.

DIMENSIONS

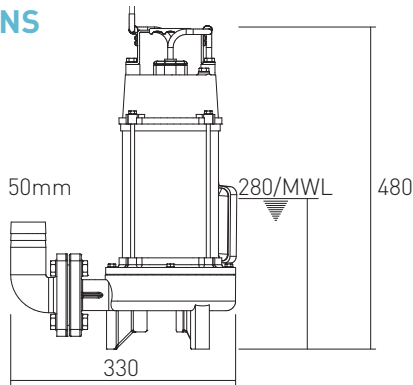

NOTES

1. All dimensions are in mm and are approximate
2. MWL = Minimum Water Level during continuous running

PERFORMANCE

