

HYFLOW® SUBMERSIBLE DRAINAGE PUMPS: HD



FEATURES

HYFLOW® Commercial - Submersible Compact Pumps are small and robust in design, perfect for recirculating or de-watering, drainage or ponds.

- > Dual seal system combines a mechanical seal and lip seal in a large capacity oil chamber
- > Stainless steel motor housing
- > Motor overheat switch to assist in protecting motor
- > Manual / Automatic configuration. ('A' designates Automatic)
- > Automatic float designed for reliable switching in dirty water applications
- > Low pump down depth (in manual operation) making it an ideal puddle pump
- > 5 metre cable
- > 25mm and 32mm hose coupling included

HD DRAINAGE DESIGN

Multi-vane semi-open impeller



30 YEARS INDUSTRY EXPERIENCE

RANGE

MODEL NUMBER	PRODUCT CODE	OUTLET	VOLTAGE	POWER	CURRENT (FLC)	WEIGHT	SOLIDS HANDLING
HD32.025.1.2	1900100	32mm	240v	0.25kW	2.2A	4.1kg	4mm
HD32.025.1A.2	1900101	32mm	240v	0.25kW	2.2A	4.1kg	4mm

DIMENSIONS

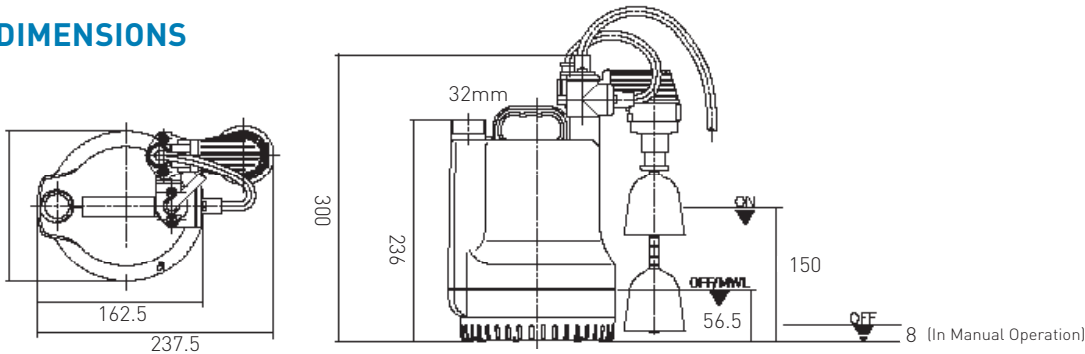

NOTES

- All dimensions are in mm and are approximate
- MWL = Minimum Water Level during continuous running

PERFORMANCE

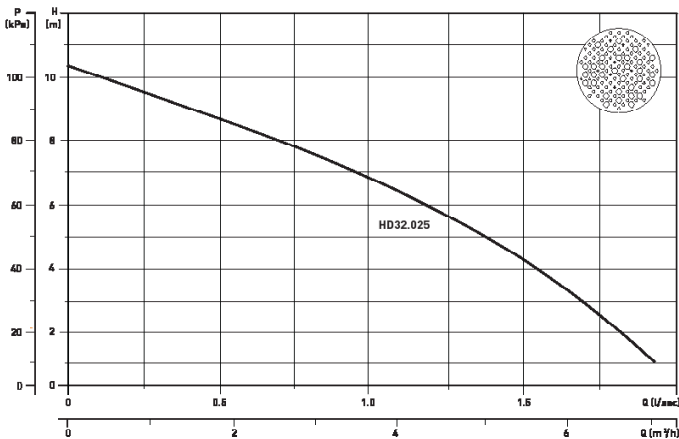

APP ADVICE	RECOMMENDATION
	STANDARD HOSE KIT
	LAY FLAT HOSE KIT

