

HYFLOW® SUBMERSIBLE DRAINAGE PUMP : HP



FEATURES

HYFLOW® Commercial - Submersible Contractors Pumps are designed for the construction industry. They are small, robust and portable in design, perfect for near complete eradication of water from building sites, flooded basements and more.

- > Heavy duty construction
- > Triplex seal system combines a SIC/SIC hard-face double mechanical seal and lip seal in a large capacity oil chamber
- > Moulded power cable base provides best protection against water ingress
- > Stainless Steel heavy rigid shaft for increased seal and bearing life
- > Motor overheat switch to assist in protecting the pump motor
- > 10 metre power cable (H07RFN submersible rubber power and float cable)

HD DRAINAGE DESIGN

Rubber coated multi-vane semi-open impeller for high abrasion resistance 

CASING & SUCTION COVER

Rubber coated for high abrasion resistance

OUTLET CONNECTION

Multi position outlet to eliminate hose kinking



30 YEARS INDUSTRY EXPERIENCE

HP25.04.1.2 (PUDDLE PUMP)

- > Removes water down to 1-2mm
- > Solids handling 2mm

RANGE

MODEL NUMBER	PRODUCT CODE	OUTLET	POWER	CURRENT (FLC)	WEIGHT
HP25.04.1.2	1900138	25mm	0.4kW	2.6A	11kg

DIMENSIONS

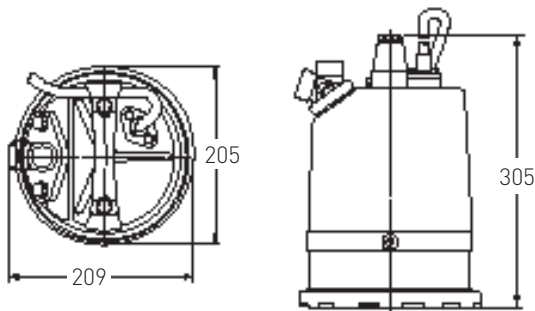

PERFORMANCE

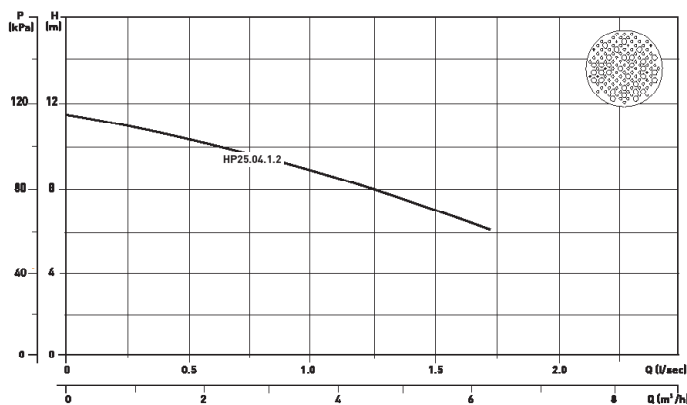

APP ADVICE	RECOMMENDATION
	STANDARD HOSE KIT
	LAY FLAT HOSE KIT

