

HYLIFT® UNDERSINK PUMPS

HYLIFT® 40



FEATURES

Compact and easy to install, the All Purpose Pumps HYLIFT® 40 units come fully assembled and plug directly into a standard electrical outlet. The heavy duty pump easily handles domestic and commercial waste and has been selected for its high performance & extremely quiet operation.

- > WaterMark Certified complying the WMTS 106:2019. Certification N°: 23399.
- > Durable 40 litre stainless steel tank.
- > 240v submersible pump, capable of handling small solids and fibres, whilst pumping high heads and long distances.
- > Compact design, supplied fully assembled with all connection points on one face.
- > Single trade installation, complete with 2 metre power cable and standard 3 pin, 240v 10 amp plug.
- > Odour filter and anti flood valve accessory* (included)
- > Optional audible visual high level alarm, 3 Mountable Positions voltage free common alarm output for BMS connection
- > 50mm FBSP Inlet
- > 25mm FBSP Discharge



30 YEARS INDUSTRY EXPERIENCE

RANGE

MODEL	PRODUCT CODE	PUMP	MAX. SOLIDS HANDLING	MAX. HEAD	VOLTAGE/KW	ADDITIONAL FEATURE
HYLIFT-40	8650023	HD32	15mm	7.0m	240V / 0.18kW	-
HYLIFT-40HLA	8650025	HD32	15mm	7.0m	240V / 0.18kW	High Level Alarm

PERFORMANCE

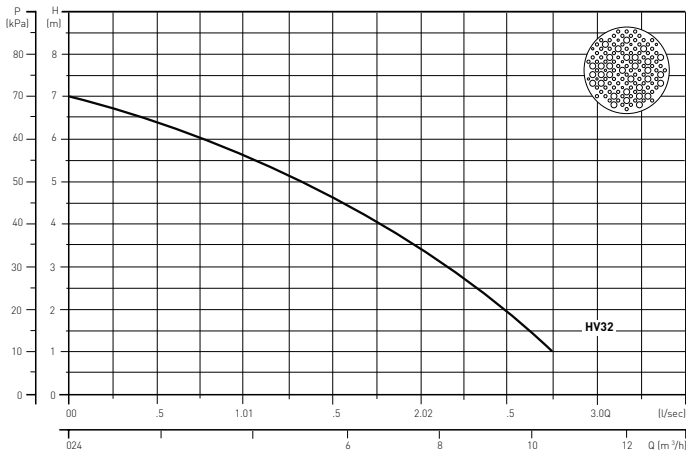

DIMENSIONS

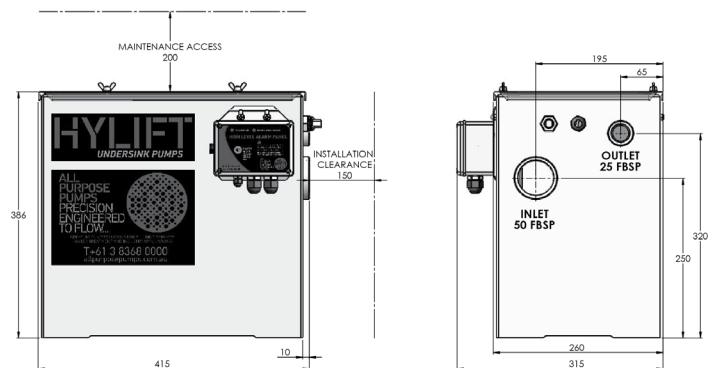

NOTES

- Dimensions in mm and are approximate
- Allow minimum of 200mm above unit for maintenance
- High level alarm needs weather protection if mounted outside

HYLIFT APPLICATION GUIDELINE

Based on typical offline amenities application

HYLIFT 40	HYLIFT 70
<ul style="list-style-type: none"> > Tight spaces and less demanding applications > Suitable for 1-30 people with one dishwasher. 	<ul style="list-style-type: none"> > High-use applications including restaurants, large office spaces, greasy and fatty wastes. > Suitable for 1-80 people with two dishwashers.

FLOOD PROTECTION & SAFETY DEVICES

- > Audible / Visual High level alarm with flexible positioning (Optional)
- > Flood Prevention Safety interlock kits (Optional - Requires High Level Alarm)
- > Unique combined Odour Filter and anti flood valve.

APP ADVICE	FEATURE	BENEFIT
	Powerful & reliable pump	<ul style="list-style-type: none"> > No need to run pump line on grade > Handles solids and fibers > Multiple bends, rises and falls in the pump line is no problem
	Odour filter & anti flood valve accessory (included)	<ul style="list-style-type: none"> > Eliminates the need for vent pipework

*NOTE

- Chemical, thinners and acidic based products will reduce the Filter service life



T +61 3 8368 0000
www.appumps.com.au

HYLIFT
UNDERSINK PUMPS